

# **H** TECHNICAL PROCEDURE

## AUXILIARY AXLE SYSTEMS

**SUBJECT:** Air Control Kit Installation Instructions

**LIT NO:** H719

**DATE:** January 2015      **REVISION:** C

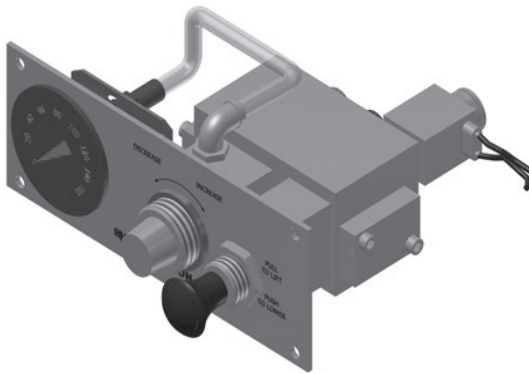

### TABLE OF CONTENTS

Introduction.....	2	Instructions for Suspension Operation .....	7
Standard Components .....	2	Frequently Asked Questions.....	8
Optional Available Components.....	2	Trouble Shooting Guide.....	9
Pre-Installation Safety Precautions.....	3	Plumbing Schematic.....	12
Installation Instructions .....	4	New Generation HAC Replacement Parts .....	13
Installation Tips.....	4	Tips and Tricks .....	14
Installation Schematic .....	5		



## INTRODUCTION

The following instructions are intended for the installation of Hendrickson HAC air kits on vehicles equipped with Hendrickson auxiliary suspensions.

**NOTE:** Read the entire installation instructions thoroughly before proceeding with an air kit installation.

For additional information concerning air kit selection, contact the Hendrickson Customer Service Department at 800-660-2829.

Alteration of an air kit or other suspension components is not permitted.

Any installation deviations must be approved, in writing, by Hendrickson's Product Engineering Department. Failure to comply with any of the above will void warranty.

## STANDARD COMPONENTS

All air kits come standard with (1) pressure protection valve and (1) quick release valve for a single lift axle application.

## OPTIONAL COMPONENTS

The following options will facilitate or enhance the installation and the operation of your air kit:

### BRAKE DEACTIVATION VALVE

A pilot valve used to allow auxiliary axle brakes (part # R-001994) to normally apply when the suspension is in the "DOWN" position. However, when the auxiliary axle is in the "UP" position, the brakes are released to eliminate hang-ups during high centering and to conserve system air pressure.

### MOUNTING BRACKET

A mounting bracket designed to accompany air kits. See pictures below.

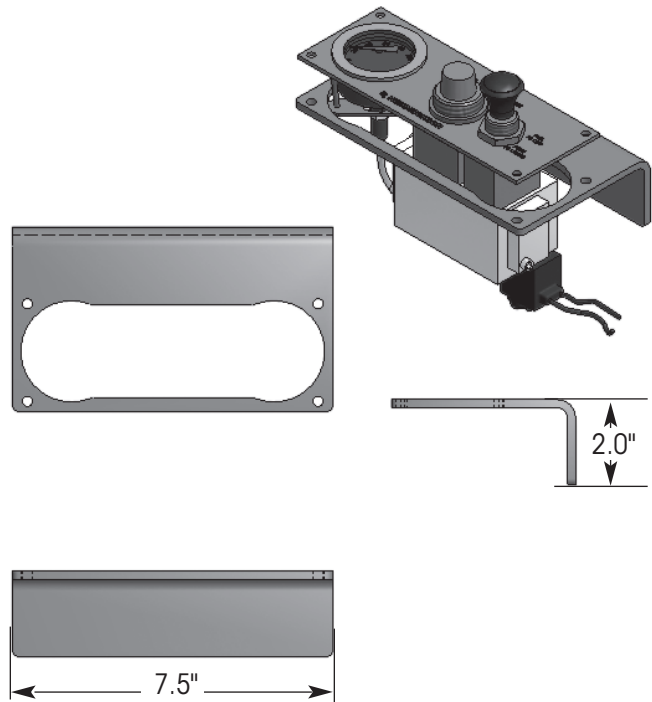
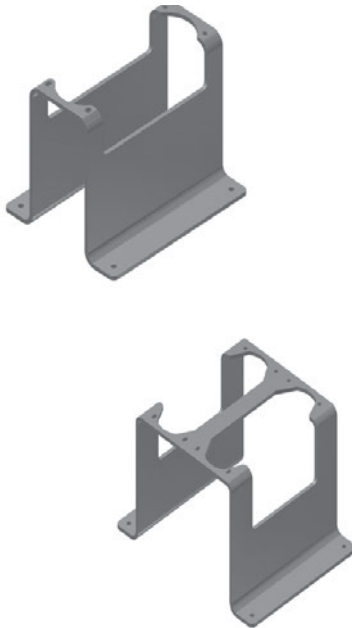

Part Number	Description
<b>R-009800-1</b>	Single mounting bracket for inside the cab.
<b>R-009800-2</b>	Double mounting bracket for inside the cab

Part Number	Description
<b>R-005771</b>	"L" shape bracket that allows you to mount the control panel on the side of the center console box (single panel application only).



### OPTIONAL COMPONENTS (CONT.)

#### ELECTRIC RELAY SWITCH

An electrical relay switch that allows the operator to control an "outside mounted" kit from inside.  
(See picture)

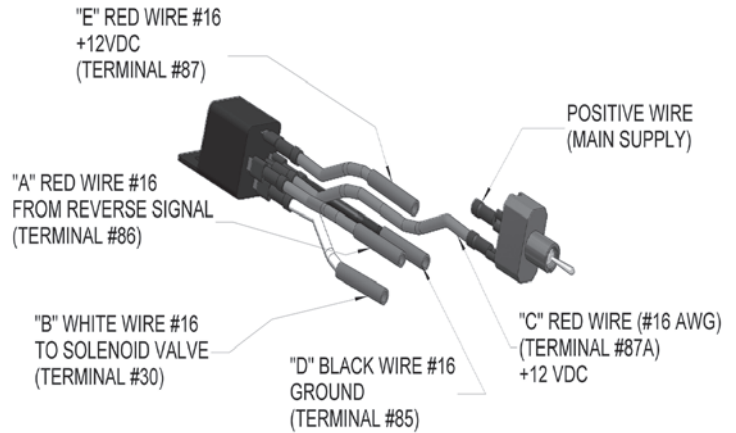
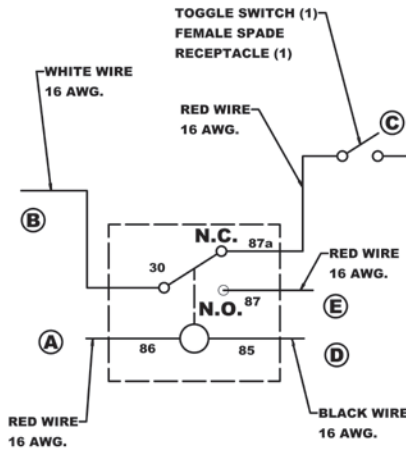

Part Number	Description
R-009791	<p><b>Relay Switch Assembly:</b> Allows the customer to raise and lower suspension from inside the cab. Comes standard with all frame mounted controls.</p> <p><b>SWITCH NOTES:</b></p> <ol style="list-style-type: none"> <li>1. Switch supplied with all outside mount air kits.</li> <li>2. For HAC-MSO, connect red wire from toggle switch to normally open (87a) terminal and eliminate red wire "E".</li> <li>3. For non-steer, do not connect wires "A" (Terminal #86) or wire "E" (Terminal #87).</li> <li>4. For non-steer suspensions, do not connect the solenoid wires to the back-up lights.</li> </ol>

### PRE-INSTALLATION SAFETY PRECAUTIONS

The warnings and cautions should be read carefully to help prevent personal injury and to assure that proper methods are used. Improper maintenance, service or repair may damage the vehicle, cause personal injury, render the vehicle unsafe in operation, or void manufacturer's warranty.

Failure to follow the safety precautions in this manual can result in personal injury and/or property damage. Carefully read and understand all safety related information within this publication, on all decals and all such materials provided by the vehicle manufacturer before conducting any maintenance, service or repair.

**⚠ WARNING: ELECTRICAL ENERGY CAN CAUSE SEVERE PERSONAL INJURY OR DEATH. DISCONNECT THE VEHICLE'S BATTERY BEFORE CONDUCTING WORK ON ANY PART OF THE VEHICLE'S ELECTRICAL SYSTEM.**

**⚠ WARNING: STORED AIR PRESSURE CAN CAUSE SEVERE PERSONAL INJURY AND COMPONENT DAMAGE. RELEASE ALL PRESSURE FROM AIR SPRINGS, AIR LINES AND OTHER APPLICABLE COMPONENTS BEFORE CONDUCTING WORK ON ANY PART OF THE VEHICLE'S AIR SYSTEM. WEAR PROPER EYE PROTECTION AT ALL TIMES.**

**⚠ WARNING: DO NOT MODIFY OR REWORK PARTS. DO NOT USE SUBSTITUTE PARTS OF THE SUSPENSION OR AXLE COMPONENTS. USE OF A MODIFIED OR REPLACEMENT PARTS NOT AUTHORIZED BY HENDRICKSON MAY NOT MEET HENDRICKSON'S SPECIFICATIONS, AND CAN RESULT IN FAILURE OF THE PART, LOSS OF VEHICLE CONTROL, AND POSSIBLE PERSONAL INJURY OR PROPERTY DAMAGE. USE ONLY HENDRICKSON AUTHORIZED REPLACEMENT PARTS DO NOT MODIFY PARTS WITHOUT AUTHORIZATION FROM HENDRICKSON.**

**⚠ WARNING: PERSONAL PROTECTIVE EQUIPMENT: ALWAYS WEAR PROPER EYE PROTECTION AND OTHER REQUIRED PERSONAL PROTECTIVE EQUIPMENT TO HELP PREVENT PERSONAL INJURY WHEN YOU PERFORM VEHICLE MAINTENANCE, REPAIR OR SERVICE.**



## INSTALLATION INSTRUCTIONS

1. Follow installation schematic for your air control.
2. Connect one solenoid black wire to a power source that is on, only when the backup lights are activated (steerables only).
3. Connect the other solenoid black (non-polarized) wire to a good vehicle ground.  
Green fittings connect to the supply tank.  
Blue fittings connect to the lift springs.  
Red fittings connect to the ride springs.  
Yellow fittings connect to the exhaust ports (for lift bags).  
Violet fittings connect the auxiliary components (where applicable).

## INSTALLATION TIPS

 **CAUTION:** Use a filter rated to at least 40 micron. Anything less could be detrimental to the air control panel.

1. Use only air brake tubes that conform to S.A.E. J844 and ensure all tubes are free from kinks.
2. Ensure that the minimum bend radii are achieved on all tubes prior to assembly.  
Recommended minimum radii:  
1/4" Tube – 1,000 inches  
3/8" Tube – 1,500 inches
3. Use only dedicated tube cutters when preparing tube ends for insertion into push-in fittings.
4. Ensure tube ends are square, free from all damage, and clean.
5. Ensure tube is fully inserted into fittings (tube ends are pushed past both the grip ring and the sealing O-ring).
6. Ensure fitted panels have enough free length of tube to ensure the tube in the fittings is not under any tension.
7. Crimp wires for all electrical connections into the butt connectors provided using an appropriate crimp tool.
8. Ensure there is sufficient free electrical cable to prevent wires and connections from being under tension.



## INSTALLATION SCHEMATIC

### HAC AIR CONTROL KITS

- Inside and outside the cab mount
- Auto lift in reverse for steerable
- Manual raise lower for non-steerable
- Push-to-connect fittings
- Non-polarized solenoid valve for steerable
- Single panel
- Outside mount comes standard with an electric relay switch for inside the cab control
- Weather tight composite and stainless box available

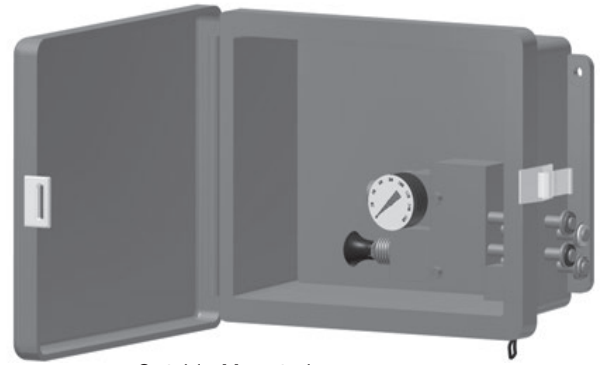

Outside Mounted Composite Box

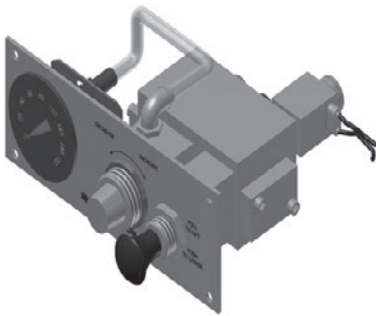

Inside Mounted



Outside Mounted Maryland Specification

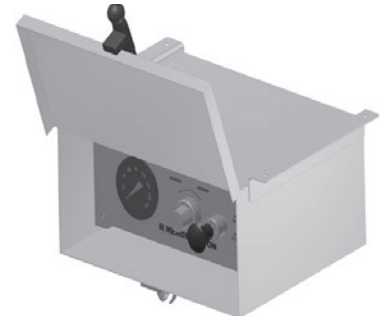



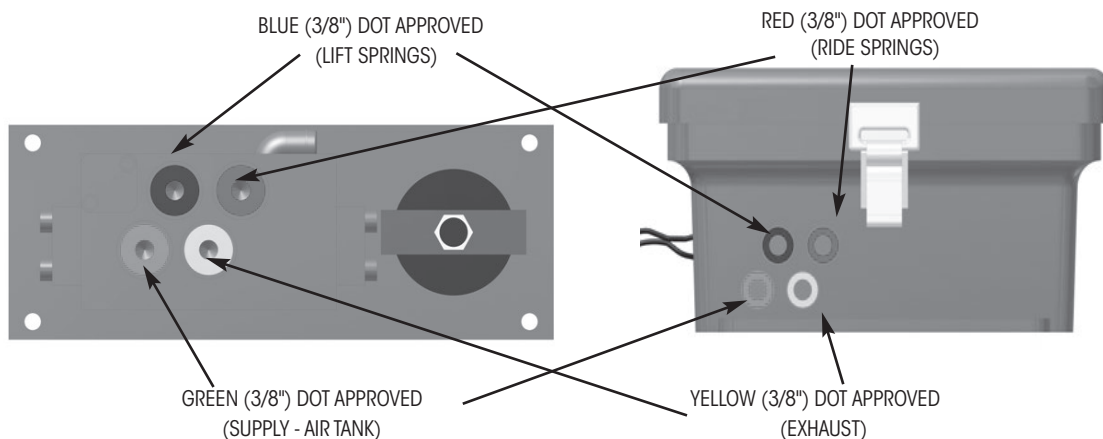

Outside Mounted Stainless Box

AIR KIT TYPE	INSIDE	OUTSIDE (COMPOSITE)	OUTSIDE (STAINLESS)
STEERABLE	HAC-SSI	HAC-UCO	HAC-USO
NON STEERABLE	HAC-NSI	HAC-UCO	HAC-USO
REVERSE LIFT & LOCK	HAC-LSI	HAC-LCO	HAC-LSO
REVERSE DOWN & LOCK	HAC-RSI	HAC-RCO	HAC-RSO
REVERSE CASTER	HAC-ASI	HAC-ACI	HAC-ASO

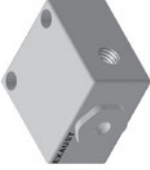

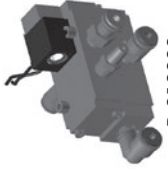
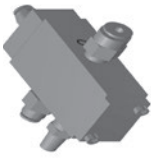

	009689	X	X	X	X	X	X	X	X	X	X
	R-004348-1	X	X	X	X	X	X	X	X	X	X
	R-009791						X	X	X	X	X
	R-010028					X				X	
	R-009790			X				X			
	R-009790-1				X				X		
	(see pg.5 for box options)	X	X	X	X	X	OUTSIDE CONTROL BOX				
	HAC-SSI										
	HAC-NSI										
	HAC-LSI										
	HAC-RSI										
	HAC-ASI										
	HAC-UCO/USO										
	HAC-LCO/LSO										
	HAC-RCO/RSO										
	HAC-ACO/ASO										
	HAC-MSO										



## INSTRUCTIONS FOR SUSPENSION OPERATION

### Raising Your Lift Axle

1. If vehicle is already running, please proceed to #6.
2. Set parking brake of truck.
3. Turn your vehicle ignition to on position.
4. Press start switch and release when engine is started.
5. Allow truck to idle until the air pressure has reached compressor cut-out pressure (usually 120 psi).

**⚠ WARNING: DO NOT RAISE OR LOWER YOUR LIFT AXLE IF TRUCK IS MOVING IN EXCESS OF 15 MPH. ASSURE AREA SURROUNDING LIFT AXLE IS CLEAR OF ANY OBSTRUCTIONS.**

6. If controls are **inside mounted**, move the Hendrickson air control panel's push/pull valve to the UP position. If controls are **outside mounted**, assure vehicle is stopped and parking brake is set. Exit vehicle, go to air control enclosure and open it. Move the control valve's lever to the up position. Repeat with electric switch to confirm function and ensure push/pull valve is in down position.
7. Visually confirm the axle is lifting.

**NOTE:** Vehicle system air pressure may drop during suspension lifting process.

8. Axle should be completely lifted when truck's air pressure returns to the air compressor cut-out point (usually 120 psi).
9. It is recommended to raise the lift axle when not in use.

### Lowering Your Lift Axle

1. If vehicle is already running, please proceed to #6.
2. Set parking brake of truck.
3. Turn your vehicle ignition to on position.
4. Press start switch and release when engine has started.
5. Allow truck to idle until the air pressure has reached compressor cut-out (usually 120 psi).

**⚠ WARNING: DO NOT RAISE OR LOWER YOUR LIFT AXLE IF TRUCK IS MOVING IN EXCESS OF 15 MPH. ASSURE AREA SURROUNDING LIFT AXLE IS CLEAR OF ANY OBSTRUCTIONS.**

6. If controls are **inside mounted**, move the control panel's push/pull valve to DOWN position. If controls are **outside mounted**, assure vehicle is stopped and parking brake is set. Exit vehicle, go to air control enclosure and open it. Move the control valve's lever to the down position. Repeat with electric switch to confirm function and ensure push/pull valve is in down position.
7. Using the regulator, adjust air pressure on gauge to appropriate air pressure for vehicle load conditions. See performance charts in the suspension owners manual (H642).

**NOTE:** Air system pressure may drop during suspension lowering process.

8. Axle should be completely lowered and supporting pre-determined load when system air compressor cut-out point is reached (usually at 120 psi).

## FREQUENTLY ASKED QUESTIONS

**NOTE:** All brake plumbing installations must adhere to FMVSS-121 regulations. Modification to a vehicle's pneumatic system may alter its compliance to FMVSS-121 regulations.

### 1. WHERE DO I INSTALL MY HENDRICKSON AIR KIT CONTROL PANEL?

The Hendrickson air kit product line is available for inside-the-cab and outside-the-cab mounting. Your particular application will be dictated by regulations in your state(s) of operation.

### 2. MY AXLE GOES DOWN AFTER THE TRUCK IS SHUT DOWN AND IT RAISES THE ENTIRE CHASSIS. CAN I MAKE THE AXLE STAY IN THE UP POSITION?

Plumb into main power from battery, not ignition switch. This will keep the power on to lift. Amp draw is 0.4 or 4.8 watts.

### 3. CAN I PLUMB MY AIR KIT IN-LINE WITH MY RIDE HEIGHT CONTROL VALVE?

A complete vehicle assessment should be conducted considering primary suspension load share and vehicle handling performance. Specific instances can be reviewed by HAUX.

### 4. AT WHAT PRESSURE SHOULD THE REGULATOR BE SET?

All new suspension and air control installations should be verified at a certified scale to determine correct air pressures vehicle loading. An average performance chart for each suspension is in the owners manual (H642). Improper vehicle loading can cause handling irregularities and component damage - Typically 70-120 psi.

### 5. HOW DO I IDENTIFY MY AIR KIT?

For inside mounted air kits, the identification tag should be located on the top of the control module. For outside mounted air kits, the identification tag should be located on the inside of the door panel (see page 8).

### 6. WHY DO STEERABLE SUSPENSIONS REQUIRE AUTOLIFT IN REVERSE?

Due to the positive caster angle built into Hendrickson steerable auxiliary axles, our air kits designed for steerable applications will automatically lift the auxiliary axle while in reverse, unless a reverse locking option is specified.

### 7. HOW DOES THE REVERSE LOCKING OPTION ENGAGE?

When utilizing the reverse locking option, the air kit automatically engages the lock feature when the vehicle is operated in reverse gear.

**NOTE:** A different air control will be required to operate the lock straight option.

### 8. HOW DO I DIRECT REGULATED PRESSURE?

With Hendrickson air kits you can direct regulated pressure (0-120 psi) through the control panel and into the auxiliary axle ride springs. Since suspension capacity, load distribution and bridge laws command the flexibility in distributing load, the versatility of the air regulator allows application needs to be met, while meeting the load distribution laws in your area of operation.

### 9. WHY DOES MY PRESSURE GAUGE SHOW RIDE PRESSURE WHEN AXLE IS RAISED?

The gauge will show a constant value for pressure dialed into the regulator. This makes technicians and operators aware of both ride pressure and stored pressure, which can cause severe personal injury and component damage. (see tips & tricks section for more information) With Hendrickson air kits please check the position of the push/pull valve to determine axle position and proper functionality.

### 10. HOW DO I DETERMINE THE FUNCTIONALITY OF EACH KIT COMPONENT?

Green fitting to supply.  
Actuator knob pulled out for lift axle raise.  
Actuator knob pushed in for lift axle lower.  
Blue fitting to lift springs.  
Red fitting to ride springs.  
Yellow exhaust for lift bags.  
Violet fitting for applicable lock components.





## TROUBLE SHOOTING GUIDE

PROBLEM	POSSIBLE CAUSE	REMEDY
<b>Automatic lift does not function</b>	Lack of air kit lubrication due to contamination	Service air kit by removing and replacing the spool with R-009796-Z or adding lubrication to existing spool (Dow III only) with part number R-010880.
	Solenoid on air kit control panel is not being energized	Connect black wire to vehicle ground and black wire to backup light power wire
	Kinked, pinched, or broken air line between air kit control panel and lift springs	Replace pinched, kinked or broken air lines
	Kinked, pinched, or broken air line between air kit control panel and supply tank	Replace pinched, kinked or broken air lines
	Supply air pressure insufficient to operate lift mechanism	Verify that you are receiving 100 psi minimum at the lift axle control panel. Use calibrated gauge at supply line inlet
	Non-functioning quick exhaust	Replace non-functioning quick exhaust valve
	Exhaust port on back of air kit control panel plugged	Remove obstruction to exhaust port on back of air control panel
	Air kit control panel not properly plumbed	Confirm that the air kit control panel is plumbed per the appropriate diagram in this book
	Non-functioning air kit control panel	Call Hendrickson warranty department at 1-800-660-2829
<b>Does not manually lift with push/pull valve on air kit control panel</b>	Lack of air kit lubrication due to contamination	Service air kit by removing and replacing the spool with R-009796-Z or adding lubrication to existing spool (Dow III only) with part number R-010880.
	Kinked or broken air line between air kit control panel and air springs	Replace pinched, kinked or broken air lines
	Kinked or broken air line between air kit control panel and supply tank	Replace pinched, kinked or broken air lines
	Supply air pressure insufficient to operate lift mechanism	Verify that you are receiving 100 psi minimum at the lift axle control panel. Use calibrated gauge at supply line inlet
	Non-functioning quick exhaust valves between ride springs	Replace non-functioning quick exhaust valve
	Exhaust port on back of air kit control panel plugged	Remove obstruction to exhaust line on back of air control panel
	Air kit control panel not properly plumbed	Confirm that the air kit control panel is plumbed per diagram in this book
	Non-functioning air kit control panel	Call Hendrickson warranty department at 1-800-660-2829



**TROUBLE SHOOTING GUIDE (continued)**

PROBLEM	POSSIBLE CAUSE	REMEDY
<b>Gauge light does not function (Older Generation; HLK only)</b>	No power to light bulb	Attach black wire to vehicle ground. Attach red wire to running light circuit
	Non-functioning light bulb	Replace light bulb
<b>Does not lower with push/pull valve on air kit control panel</b>	Lack of air kit lubrication due to contamination	Service air kit by removing and replacing the spool with R-009796-Z or adding lubrication to existing spool (Dow Ill only) with part number R-010880.
	Regulator turned down too low	Increase air pressure at regulator until desired load is carried at wheels
	Truck in reverse gear	Place transmission in forward gear or neutral
	Solenoid valve on back of air kit control panel energized	Place transmission in forward gear or neutral
	Kinked, pinched, or broken air line between air kit control panel and ride springs	Replace pinched, kinked or broken air lines
	Kinked, pinched, or broken air line between air kit control panel and supply tank	Replace pinched, kinked or broken air lines
	Supply air pressure insufficient to operate lower mechanism	Verify that you are receiving 100 psi minimum at the lift axle control panel. Use calibrated gauge at supply line inlet
	Exhaust port on back of air kit control panel plugged	Remove obstruction to exhaust port on back of air control panel
	Air kit control panel not properly plumbed	Confirm that the air kit control panel is plumbed per diagram in this book
Non-functioning air kit control panel	Call Hendrickson warranty department at 1-800-660-2829	
<b>Slow lift or lower times</b>	Lack of air kit lubrication due to contamination	Service air kit by removing and replacing the spool with R-009796-Z or adding lubrication to existing spool (Dow Ill only) with part number R-010880.
	Insufficient air flow or volume being delivered to air kit control panel	Increase incoming air line size or Increase air reservoir capacity
	Insufficient air flow or volume being delivered to the air springs	Increase air line size going to air springs; 3/8" air lines.



## TROUBLE SHOOTING GUIDE (continued)

PROBLEM	POSSIBLE CAUSE	REMEDY
<b>Quick release valve failure</b>	Clogged or plugged quick exhaust valves	Remove obstruction or replace defective quick exhaust valve (R-004348-1)
<b>Suspension does not carry rated load</b>	Insufficient air pressure in ride springs	Increase pressure in ride springs by increasing regulator setting. Check pressure in ride springs at air spring inlet
	Supply air pressure insufficient to carry rated load	Verify that you are receiving 100 psi minimum at the lift axle control panel. Use calibrated gauge at supply line inlet
	Kinked, pinched or broken hose between air kit control panel and ride springs	Replace pinched, kinked or broken air lines
	Kinked, pinched or broken hose between air kit control panel and supply tank	Replace pinched, kinked or broken air lines
	Non-functioning air kit control panel	Call Hendrickson warranty department at 1-800-660-2829
	Incorrect ride height	Call Hendrickson Technical Service Department at 1-800-660-2829



## PLUMBING SCHEMATIC

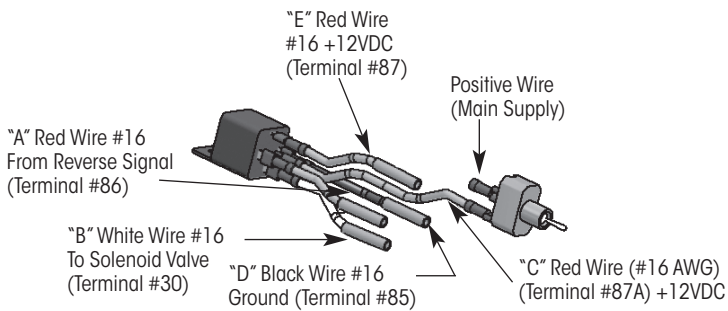
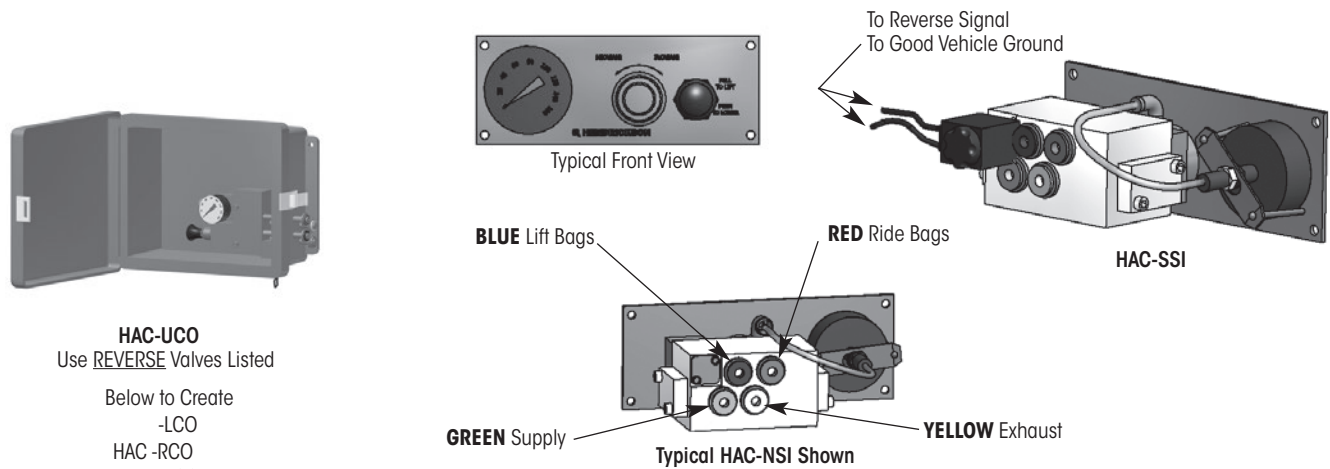
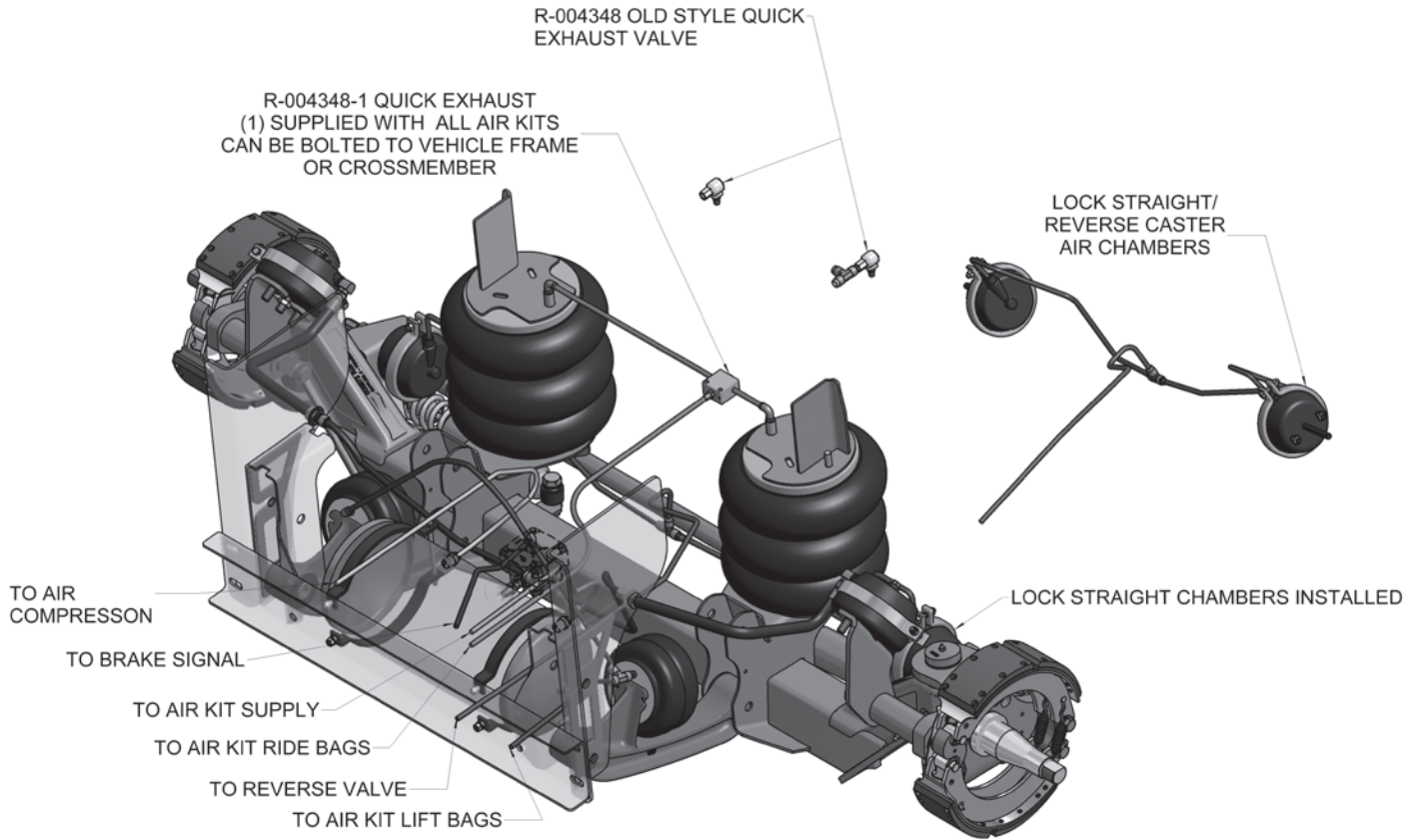

Supplied With All Outside Mounted Air Kit

Continued to Top of Page 13

Switch Notes:

1. Switch supplied with all outside mount air kits
2. For HAC-MSO, connect red wire from toggle switch to normally open (87a) terminal and eliminate red wire "E"
3. For non-steer, do not connect wires "A" (terminal #86) or wire "E" (terminal #87)
4. For non-steer suspensions do not connect the solenoid wires to the back-up lights



# HAC INSTALLATION PROCEDURES

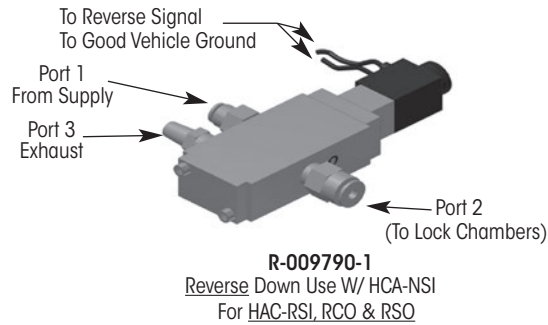
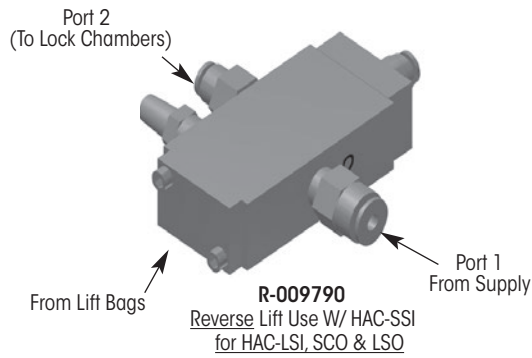

**R-009689 Pressure Protection Valve** Supplied with All Air Kits Plumb Off Air Tank To Lift Axle Air Supply (Green Port)

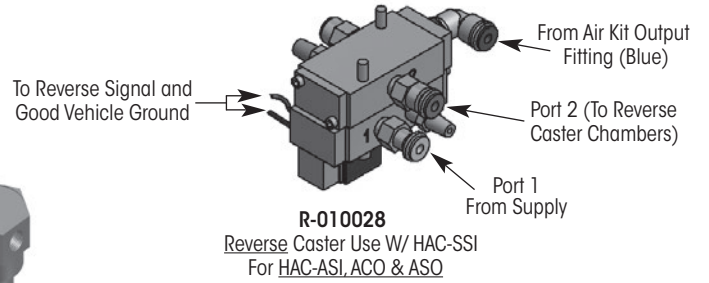

## NEW GENERATION HAC REPLACEMENT PARTS

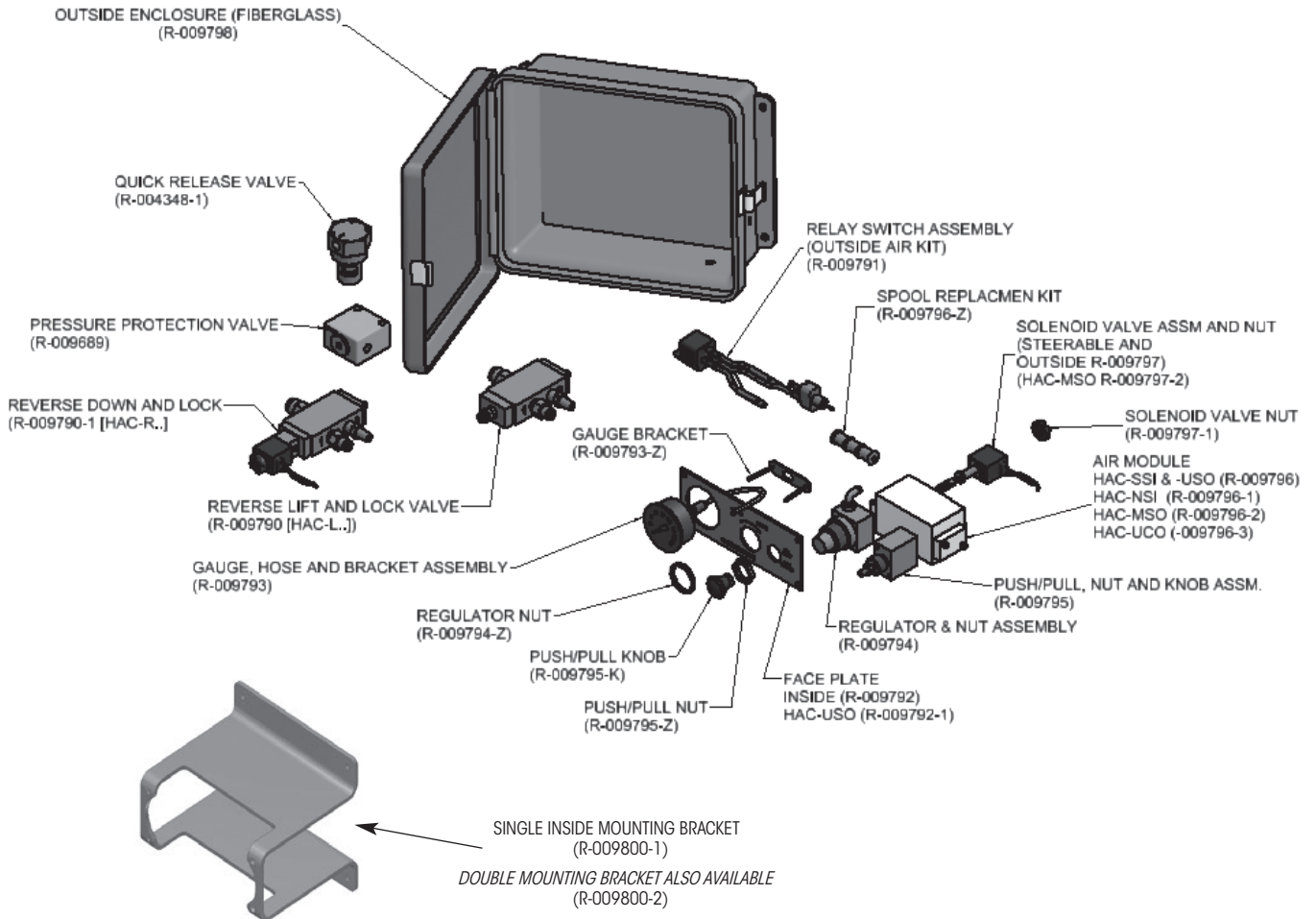





Call Hendrickson at **800.660.2829** or **800.668.5360** in Canada for additional information and application specifications.



[www.hendrickson-intl.com](http://www.hendrickson-intl.com)

**SPECIALTY PRODUCTS - AUXILIARY AXLE SYSTEMS**

277 North High Street  
Hebron, OH 43025 USA  
800.660.2829  
740.929.5600 • Fax 740.929.5601

**Hendrickson Canada**

250 Chrysler Drive, Unit #3  
Brampton, ON Canada L6S 6B6  
800.668.5360  
905.789.1030 • Fax 905.789.1033