

INITIAL CALIBRATION, OPERATION & MAINTENANCE

Initial Calibration

- 1) Ensure that the pop-safety valve is working properly.
 - a) Check that the pop-safety valve releases pressure properly at the set pressure of 15 PSI.
 - i) Make sure that the oil dispense ball valve is turned to the “OFF” position.
 - ii) Make sure that the air supply ball valve is turned to the “ON” position.
 - iii) Turn regulator knob clockwise, increasing the pressure to 15 PSI.
 - iv) At this point, the pop-safety valve should release air pressure.
 - v) If pop-safety valve works properly, turn regulator counter clockwise until pressure is between 5-8 PSI.
 - vi) If pop-safety valve does not work properly, replace.
 - (1) **CAUTION: Do not remove pop-safety valve while system is pressurized!**
 - (2) Before removing pop-safety valve, de-pressurize Chain Oiler system by following these instructions:
 - (a) First, turn supply air ball valve to the “OFF” position.
 - (b) Then, pull ring on the pop-safety valve to completely release pressure.
- 2) Check reservoir oil level, see ‘Filling the Reservoir’ instructions below if oil is needed.
- 3) Turn regulator off (zero pressure) by turning the knob all the way counter-clockwise.
- 4) Turn air supply ball valve to “ON” position.
- 5) Turn regulator knob clockwise, slowly increasing pressure between 5-8 PSI depending on desired flow rate.
- 6) Turn oil dispense ball valve to “ON” position.
- 7) Once oil starts exiting plastic tube, the pressure can still be adjusted until desired flow is achieved.
- 8) Recommended flow is 4-20 drops per minute. Actual desired rate can vary based on belt speed and operational requirements.

Standard Operation

- 1) **CAUTION: Do not exceed 15 PSI!**
- 2) After initial calibration, operate by turning the oil dispense ball valve to the “ON” or “OFF” position.
- 3) Standard operation pressure range is between 5-8 PSI. The operating pressure may need to be increased or decreased to maintain desired flow based on the viscosity of oil and speed of belt. Viscosity will vary with temperature.
- 4) Refer to Owner’s Manual for chain lubrication frequency and guidelines.

Filling the Reservoir

- 1) **CAUTION: Do not remove cap while system is pressurized!**
- 2) To fill reservoir, the Chain Oiler system must be de-pressurized by following these instructions:
 - a) First, turn supply air ball valve to the “OFF” position.
 - b) Then, pull ring on the pop-safety valve to completely release pressure.
- 3) The system is filled with “Food Grade” ChevronTexaco general purpose lubricating oil type FM ISO 32 (USDA H1 Food Grade equivalent).
- 4) Non-Food Grade oil can be substituted in applications not requiring “Food Grade” Lubricant.
- 5) Temperature vs. Viscosity Table

Temperature (Degree °F)	Recommended Lubricant SAE	Recommended Lubricant ISO
-20 to 20	SAE 10	ISO 32
20 to 40	SAE 20	ISO 46
40 to 100	SAE 30	ISO 100
100 to 120	SAE 40	ISO 150
120 to 140	SAE 50	ISO 220

Table 1 – Chain Lubricant Guide

Maintenance

- 1) Pressure may need to be adjusted as temperature changes. Temperature affects the viscosity which will affect flow rate.
- 2) Every 15,000 miles or three months (whichever comes first)
 - a) Check to make sure mounting hardware and fasteners are not loose. Tighten as necessary.
 - b) Check plastic tubing for wear and cracks. Replace as necessary.
 - c) Check that the pop-safety valve releases pressure properly at the set pressure of 15 PSI.
 - i) Make sure that the oil dispense ball valve is turned to the “OFF” position.
 - ii) Make sure that the air supply ball valve is turned to the “ON” position.
 - iii) Turn regulator knob clockwise, increasing the pressure to 15 PSI.
 - iv) At this point, the pop-safety valve should release air pressure.
 - v) If pop-safety valve works properly, turn regulator counter clockwise until pressure is between 5-8 PSI.
 - vi) If pop-safety valve does not work properly, replace.
 - (1) **CAUTION: Do not remove pop-safety valve while system is pressurized!**
 - (2) Before removing pop-safety valve, de-pressurize Chain Oiler system by following these instructions:
 - (a) Turn supply air ball valve to the “OFF” position.
 - (b) Pull ring on the pop-safety valve to completely release pressure.

FIGURE 1

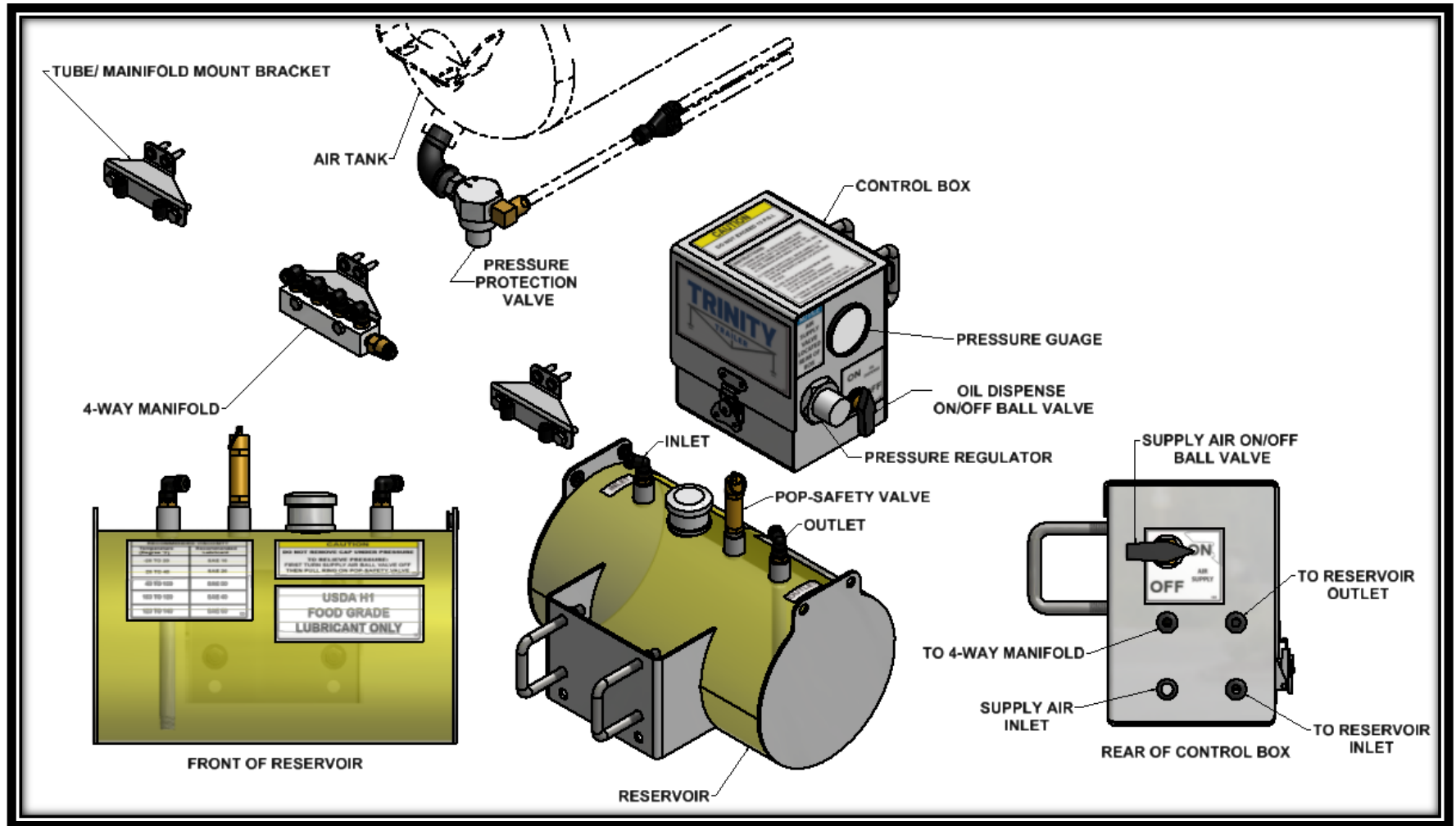

FIGURE 2

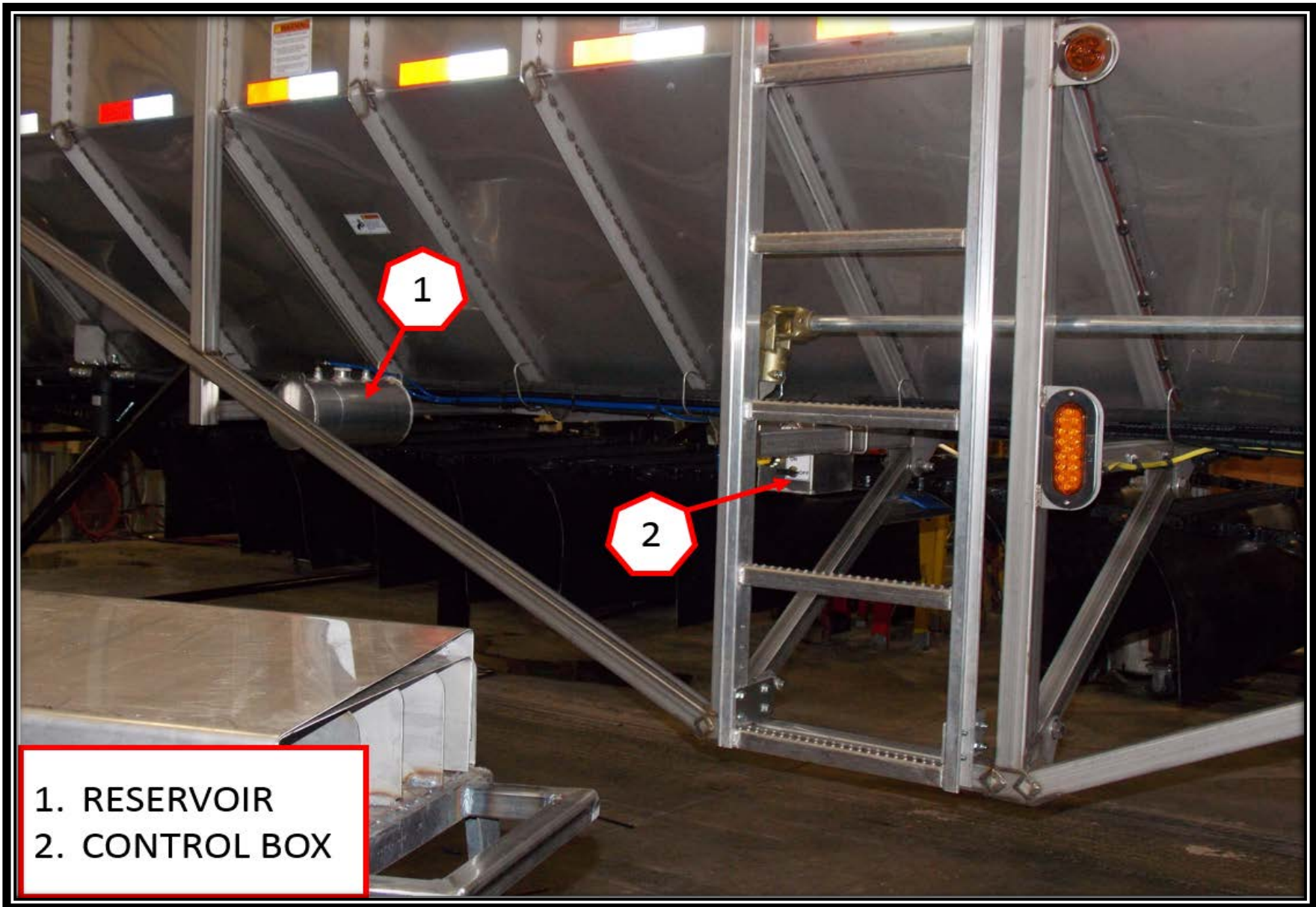

FIGURE 3

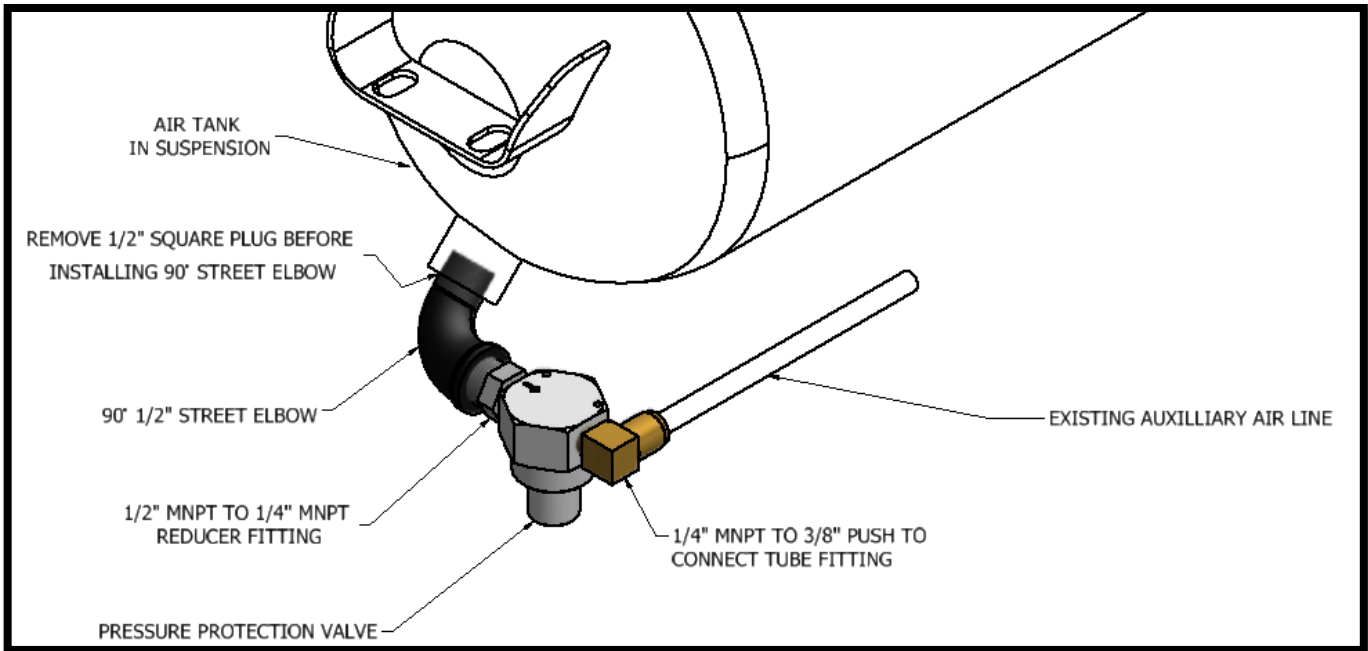

FIGURE 4

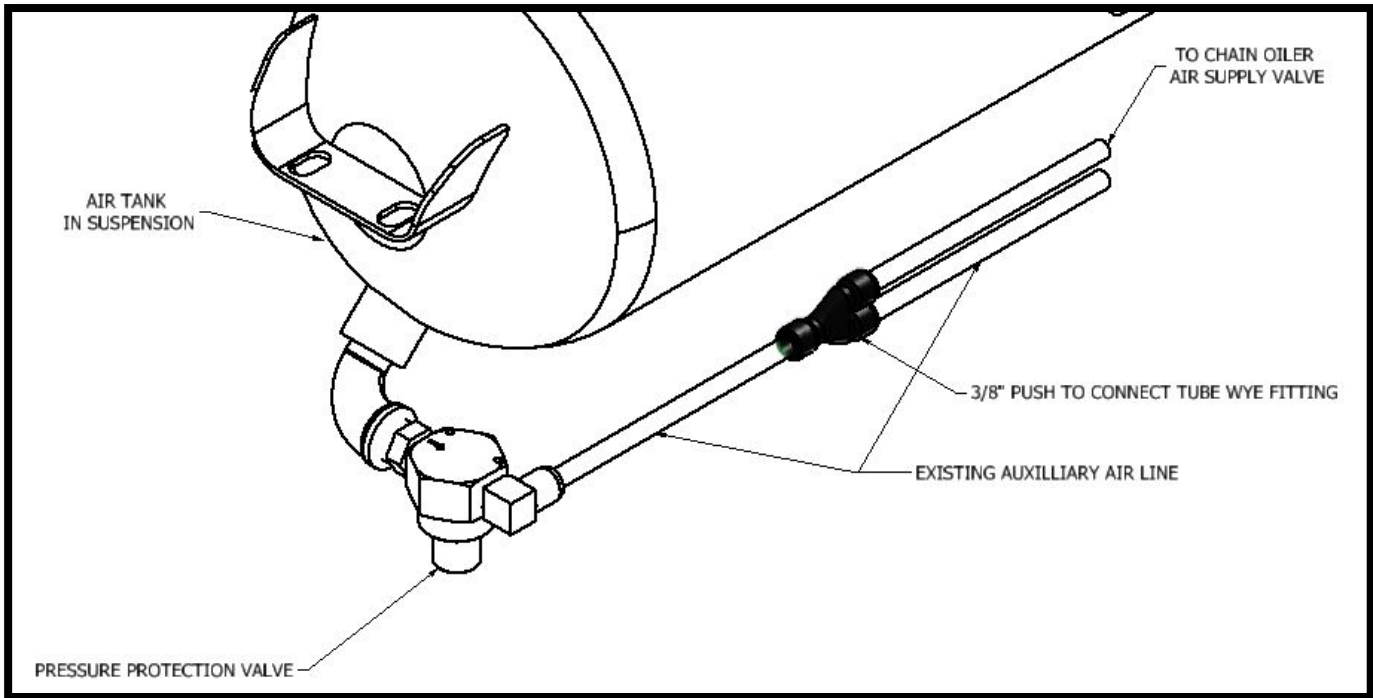



FIGURE 5



FIGURE 6

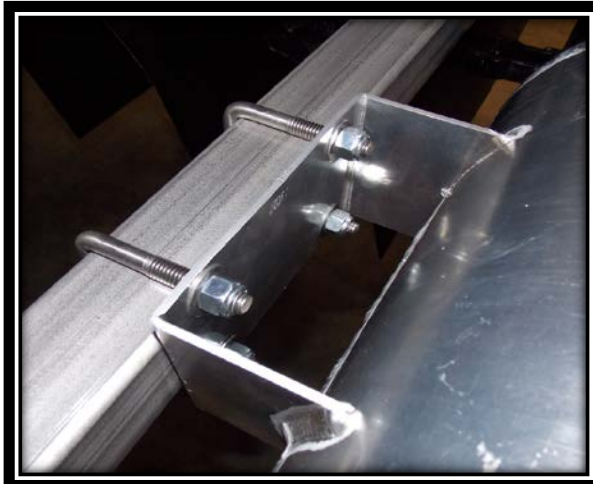

FIGURE 7

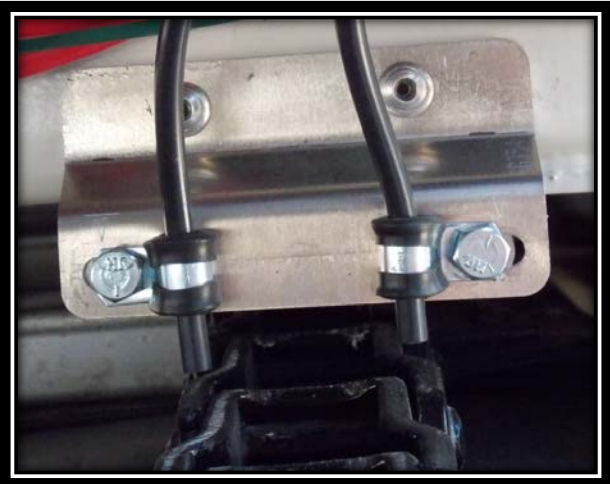

FIGURE 8

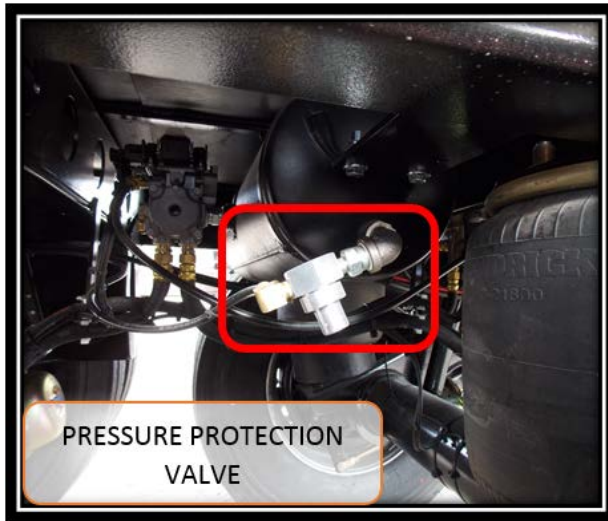

FIGURE 9



FIGURE 10

FIGURE 11

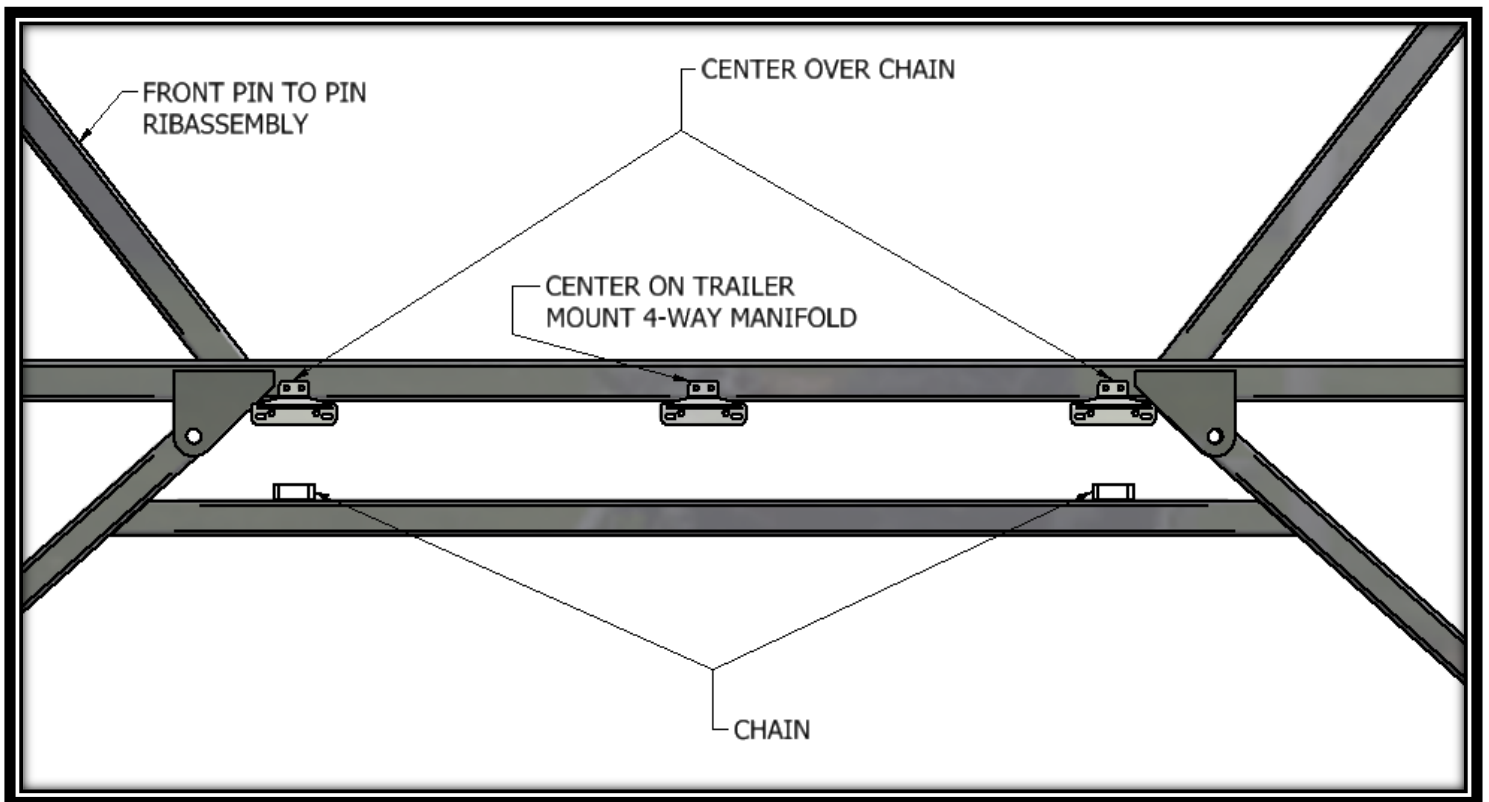

FIGURE 12

